

Note!

Before installing this product, check the contents of the kit. If anything is missing, please check an Öhlins dealer.

Kit Contents

Description	Part No	Pcs
Shock absorber	CF484	1
Tie rap	60231-01	3
Screw M6x14	00382-16	1
Screw M8x25	01046-74	2
Screw M6x12	05404-01	2
Bracket	60006-62	1
Bracket reservoir	03102-15	1
C-spanner S46	60710-02	1
Sticker set "ÖHLINS"	10207-01	1
Owners manual	07251-02	1

Note!

Please note that this image is a general representation of the product and may differ slightly from your product.

Note!

Please note that during storage and transportation, especially at high ambient temperature, some of the oil and grease used for assembling may leak and stain the packaging. This is in no way detrimental to the product, wipe off the excessive oil/grease with a cloth.

Warning!

Before installing this product, read the Öhlins Owner's Manual. The shock absorber is an important part of your vehicle and will affect the stability.

Shock Absorber for CFMOTO 450MT

CF 484

Mounting Instructions



MOUNTING INSTRUCTIONS

⚠ Warning!

It is advisable to have an Öhlins dealer install the shock absorber.

⚠ Warning!

If working on a raised vehicle, ensure it is securely supported so that it will not tip over.

👁 Note!

Before mounting this product clean the vehicle thoroughly.

👁 Note!

When working on this product, always see the Vehicle Service Manual for vehicle specific procedures and important data.

1.

Put the motorcycle on a work stand so that the rear wheel barely touches the ground. Make sure the motorcycle is in a stable position.

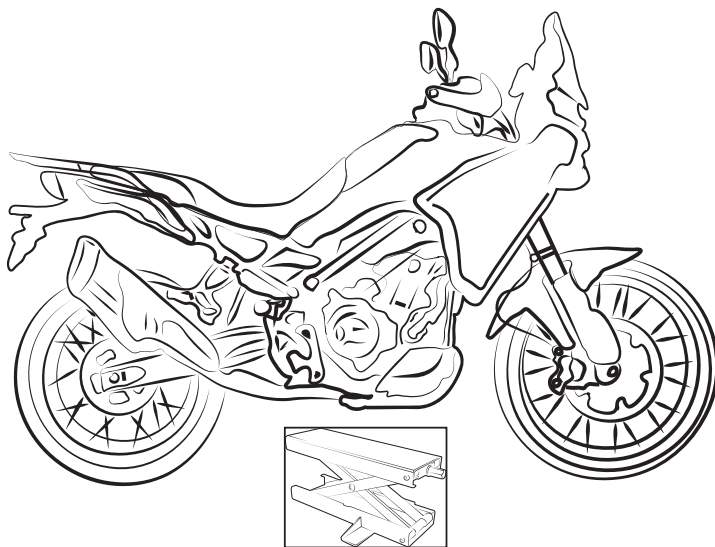

MOUNTING INSTRUCTIONS

2.

Remove the standard shock absorber according to CFMOTO workshop manuals.

3.

Install the Öhlins shock absorber. Tighten top and lower mounting bolts according to owner manual torque value.

4.

Mount the reservoir according to the picture with the supplied brackets (60006-62 and 03102-15), screws (00382-16 and 05404-01) behind right foot peg bracket. Replace standard screws ① with supplied screws 01046-74 and tighten at a torque value as specified in the vehicle service manual.

5.

Ensure the hose is clear of all obstructions and sharp bends. Secure it with tie raps as needed.

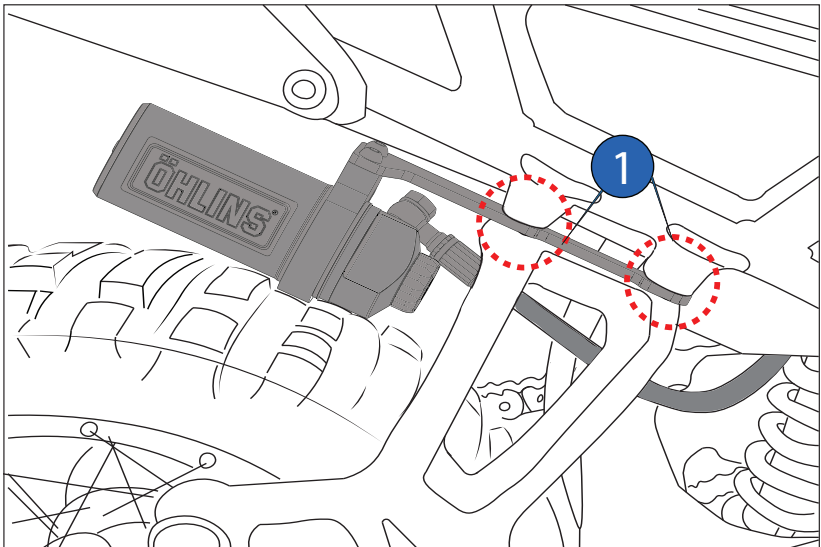

ADJUSTMENTS

⚠ Warning!

Before riding, always make sure that the basic settings made by Öhlins are according to recommended Set-up Data. Read about adjustments and setting up in the Öhlins Owner's Manual before you make any adjustments. Contact an Öhlins dealer if you have any questions about setting up.

⚠ Warning!

Do not exceed the maximum loading capacity recommended by the motorcycle manufacturer.

SET-UP DATA

Spring	Installed spring
Part No	61099-31
Free spring length...	220 mm.
Spring rate.....	95 N/mm
Preload adj.range....	[0-17] mm

Recommended set-up

Spring Preload.....	8 mm.
Rebound adjuster	14 Clicks
Compression adjuster...	16 Clicks

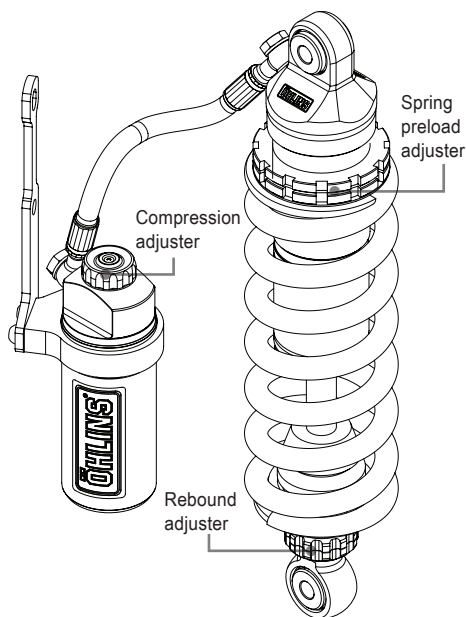

Shock absorber data

Length	350 mm.
Stroke	85 mm.

👁 Öhlins products are subject to continuous improvement and development, therefore, although these instructions include the most up-to-date information available at the time of printing, minor updates may occur.

To find the latest information contact an Öhlins distributor. Please contact Öhlins if you have any questions regarding the contents in this document.

Part no. MI_CF 484_EN_0
Issued 2025-05-26

© Öhlins Asia Co. Ltd. All rights reserved. Any reprinting or unauthorized use without the written permission of Öhlins Racing AB is prohibited.

Öhlins Asia Co. Ltd
700/937 Moo5, Tambol Nongkhaga,
Amphur Phantong, Chonburi Province
20160 Thailand



www.ohlins.com